

SOT-89-3L Plastic-Encapsulate Voltage Regulator

CJ78L12 Three-terminal positive voltage regulator

FEATURES

- Maximum output current
I_{OM}: 0.1A
- Output voltage
V_O: 12V
- Continuous total dissipation
P_D: 0.6 W (T_a= 25 °C)

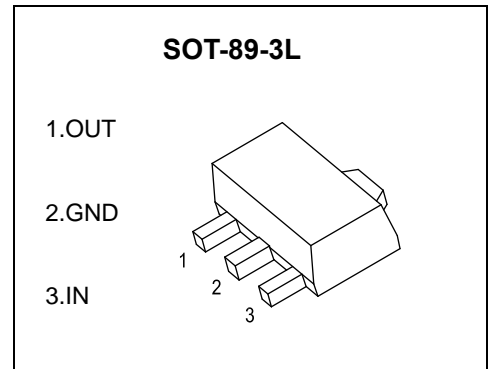

MARKING

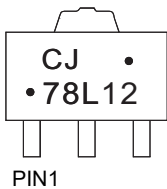

CJ78L12=Device code
PIN1 Solid dot = Green molding compound device if none, the normal device.

ABSOLUTE MAXIMUM RATINGS (Operating temperature range applies unless otherwise specified)

Parameter	Symbol	Value	Unit
Input Voltage	V _i	35	V
Thermal Resistance from Junction to Ambient	R _{θJA}	166.7	°C/W
Operating Junction Temperature Range	T _{OPR}	-40~+125	°C
Storage Temperature Range	T _{STG}	-65~+150	°C

ELECTRICAL CHARACTERISTICS AT SPECIFIED VIRTUAL JUNCTION TEMPERATURE ($V_i=19V$, $I_o=40mA$, $C_i=0.33\mu F$, $C_o=0.1\mu F$, unless otherwise specified)

Parameter	Symbol	Test conditions	MIN	TYP	MAX	UNIT
Output voltage	V_o	$T_j=25^\circ C$	11.64	12	12.36	V
		$14V \leq V_i \leq 27V, I_o=1mA-40mA$	11.4	12	12.6	V
		$I_o=1mA-70mA$	11.4	12	12.6	V
Load Regulation	ΔV_o	$I_o=1mA-100mA, T_j=25^\circ C$		22	100	mV
		$I_o=1mA-40mA, T_j=25^\circ C$		13	50	mV
Line regulation	ΔV_o	$14.5V \leq V_i \leq 27V, T_j=25^\circ C$		55	250	mV
		$16V \leq V_i \leq 27V, T_j=25^\circ C$		49	200	mV
Quiescent Current	I_q	$T_j=25^\circ C$		4.3	6.5	mA
Quiescent Current Change	ΔI_q	$16V \leq V_i \leq 27V$			1.5	mA
	ΔI_q	$1mA \leq I_o \leq 40mA$			0.1	mA
Output Noise Voltage	V_N	$10Hz \leq f \leq 100KHz, T_j=25^\circ C$		70		$\mu V/V_o$
Ripple Rejection	RR	$15V \leq V_i \leq 25V, f=120Hz$	37	42		dB
Dropout Voltage	V_d	$T_j=25^\circ C$		1.7		V

* Pulse test.

TYPICAL APPLICATION

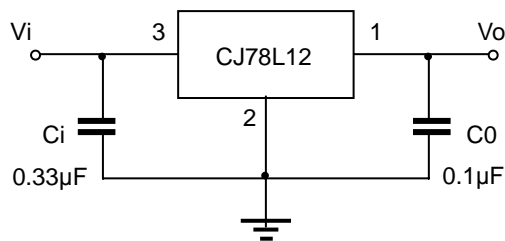

Note : Bypass capacitors are recommended for optimum stability and transient response and should be located as close as possible to the regulators.

Typical Characteristics

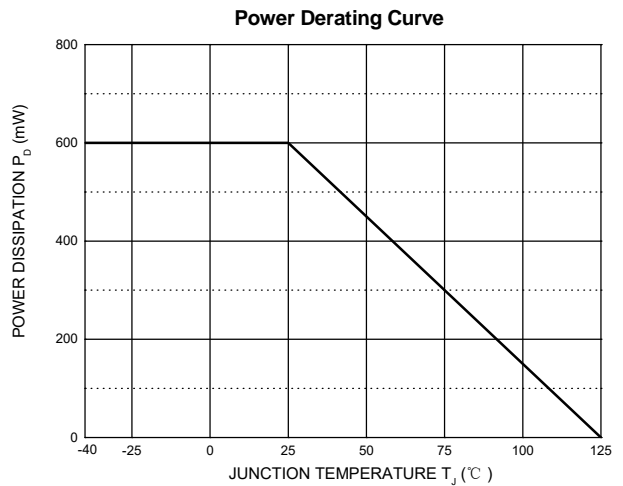
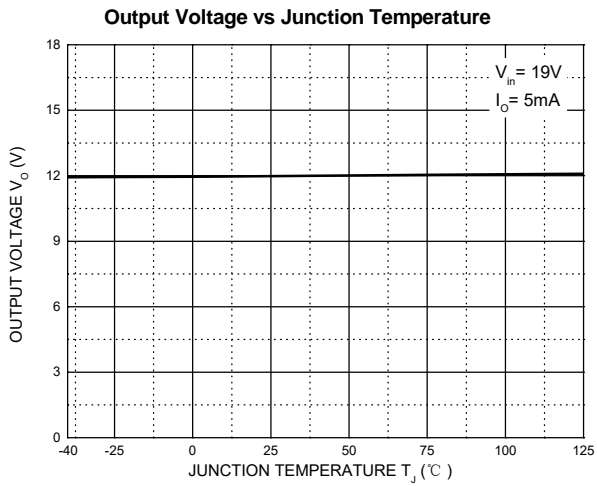
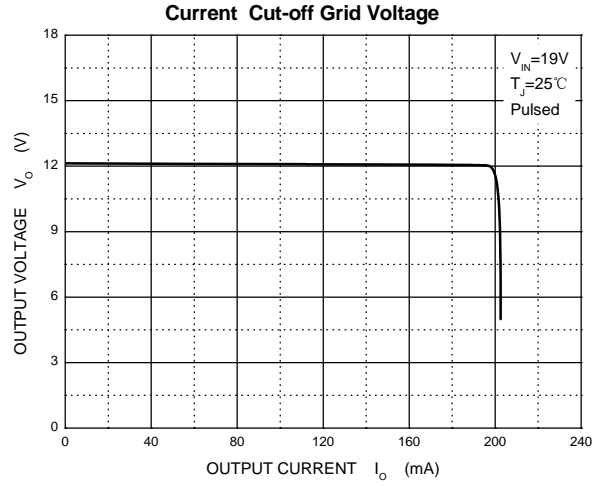
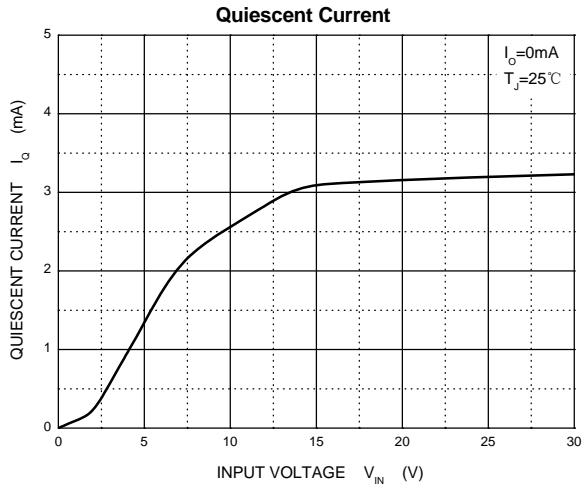
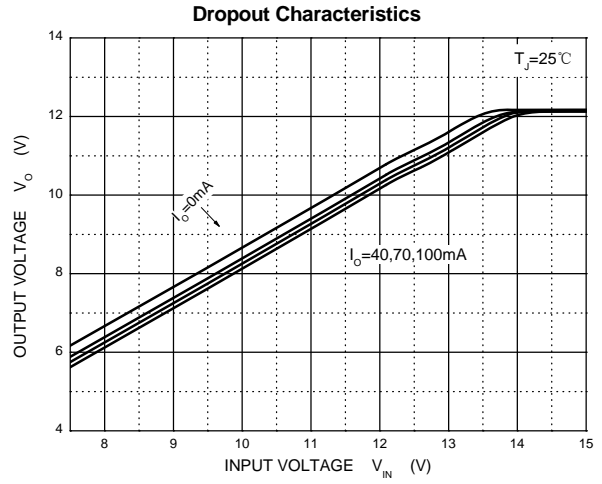
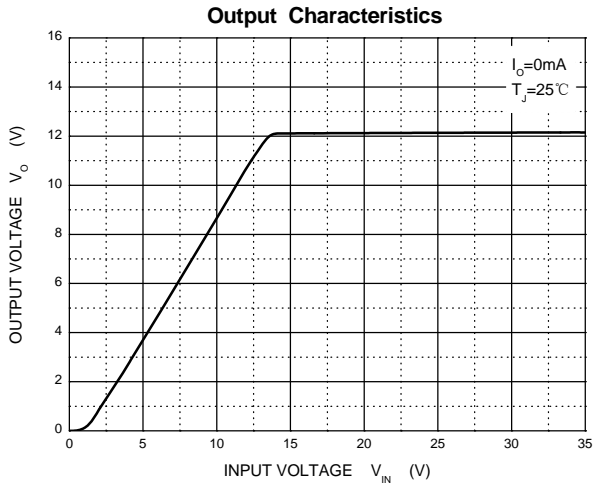

SOT-89-3L Package Outline Dimensions

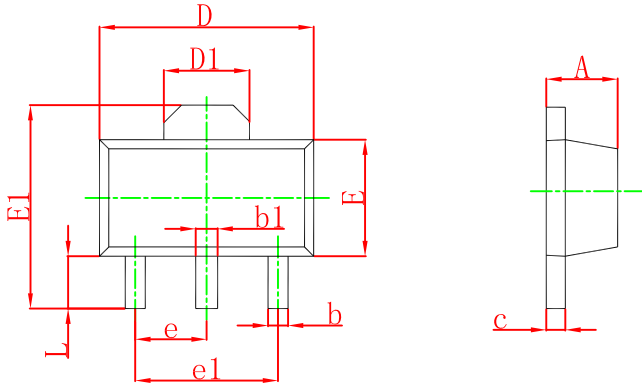

Symbol	Dimensions In Millimeters		Dimensions In Inches	
	Min	Max	Min	Max
A	1.400	1.600	0.055	0.063
b	0.320	0.520	0.013	0.020
b1	0.400	0.580	0.016	0.023
c	0.350	0.440	0.014	0.017
D	4.400	4.600	0.173	0.181
D1	1.550 REF.		0.061 REF.	
E	2.300	2.600	0.091	0.102
E1	3.940	4.250	0.155	0.167
e	1.500 TYP.		0.060 TYP.	
e1	3.000 TYP.		0.118 TYP.	
L	0.900	1.200	0.035	0.047

SOT-89-3L Suggested Pad Layout

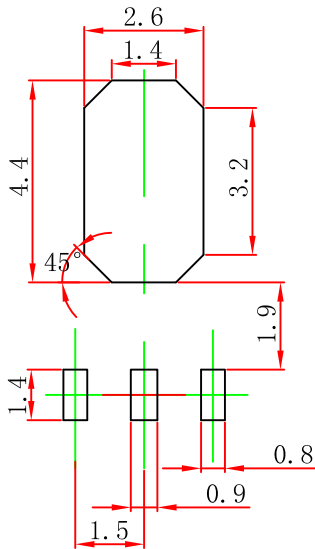

Note:

1. Controlling dimension: in millimeters.
2. General tolerance: $\pm 0.05\text{mm}$.
3. The pad layout is for reference purposes only.

SOT-89-3L Tape and Reel

SOT-89-3L Embossed Carrier Tape

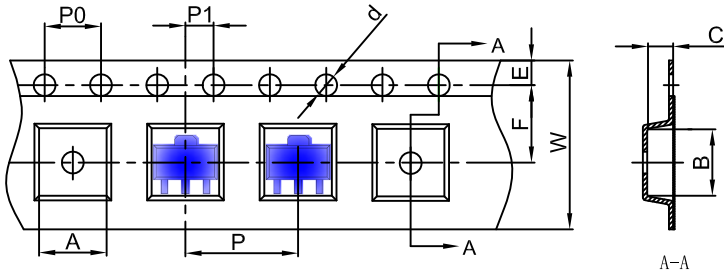

Packaging Description:
 SOT-89-3L parts are shipped in tape. The carrier tape is made from a dissipative (carbon filled) polycarbonate resin. The cover tape is a multilayer film (Heat Activated Adhesive in nature) primarily composed of polyester film, adhesive layer, sealant, and anti-static sprayed agent. These reeled parts in standard option are shipped with 1,000 units per 7" or 18.0 cm diameter reel. The reels are clear in color and is made of polystyrene plastic (anti-static coated).

Dimensions are in millimeter										
Pkg type	A	B	C	d	E	F	P0	P	P1	W
SOT-89-3L	4.85	4.45	1.85	Ø1.50	1.75	5.50	4.00	8.00	2.00	12.00

SOT-89-3L Tape Leader and Trailer

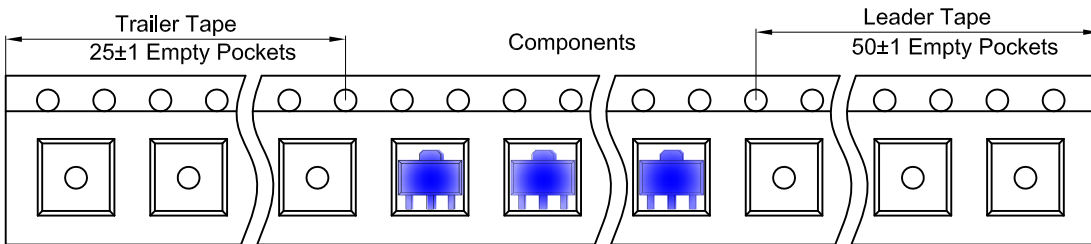

SOT-89-3L Reel

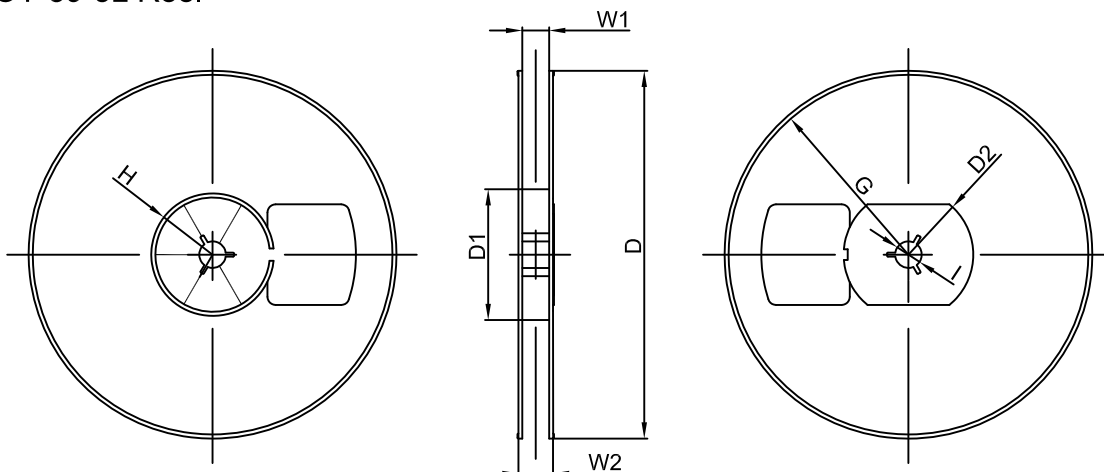

Dimensions are in millimeter								
Reel Option	D	D1	D2	G	H	I	W1	W2
7" Dia	Ø180.00	60.00	R32.00	R86.50	R30.00	Ø13.00	13.20	16.50

REEL	Reel Size	Box	Box Size(mm)	Carton	Carton Size(mm)	G.W.(kg)
1000 pcs	7 inch	10,000 pcs	203×203×195	40,000 pcs	438×438×220	

DISCLAIMER

IMPORTANT NOTICE, PLEASE READ CAREFULLY

The information in this data sheet is intended to describe the operation and characteristics of our products. JSCJ has the right to make any modification, enhancement, improvement, correction or other changes to any content in this data sheet, including but not limited to specification parameters, circuit design and application information, without prior notice.

Any person who purchases or uses JSCJ products for design shall: 1. Select products suitable for circuit application and design; 2. Design, verify and test the rationality of circuit design; 3. Procedures to ensure that the design complies with relevant laws and regulations and the requirements of such laws and regulations. JSCJ makes no warranty or representation as to the accuracy or completeness of the information contained in this data sheet and assumes no responsibility for the application or use of any of the products described in this data sheet.

Without the written consent of JSCJ, this product shall not be used in occasions requiring high quality or high reliability, including but not limited to the following occasions: medical equipment, automotive electronics, military facilities and aerospace. JSCJ shall not be responsible for casualties or property losses caused by abnormal use or application of this product.

Official Website: www.jscj-elec.com

Copyright © JIANGSU CHANGJING ELECTRONICS TECHNOLOGY CO., LTD.